



MODEL: SP-1810
PRODUCT: Dynamic Speaker
EDITION: A/2016

THIS SPECIFICATION COVERS OUR PRODUCT OF DYNAMIC SPEAKER UNIT FOR MOBILE PHONE USE

DYNAMIC SPEAKER ELECTROACOUSTIC CHARACTERISTICS

sound pressure level	82±3dB SPL @1.0, 1.2, 1.5 and 2.0KHz in average (0dB SPL=20μPa)
measuring condition	0.1W (Sine wave) 10cm measured with baffle shown in Fig.1
ac impedance	8±15%Ω (@ 2 KHz 1V) without baffle
frequency response curve	As shown in Fig.2
response frequency	1000 ± 20% Hz @ 1V. (Without Baffle)
rated noise power	0.5W
short-term max. power	1.0W must be normal at a white noise (1W, F ₀ -20KHz) for 1 minute
distortion	Less than 10% @1KHz , 0.1M , 0.1W frequency range, input level up to 0.1W
operation test	Must be free of audible noise (buzzes and rattles) 300 ~ 8KHz frequency range, input level up to 0.2Vrms

GENERAL SPECIFICATIONS

operating temperature range	-20°C ~ +60°C
storage temperature range	-30°C ~ +70°C
standard test conditions	
temperature	17°C ~ 25°C
relative humidity	45% ~ 80%(RH)
dimension	18 x 10 x 4.1mm

MEASURING METHOD (SPEAKER MODE) (Figure 1)

Standard test condition of speaker

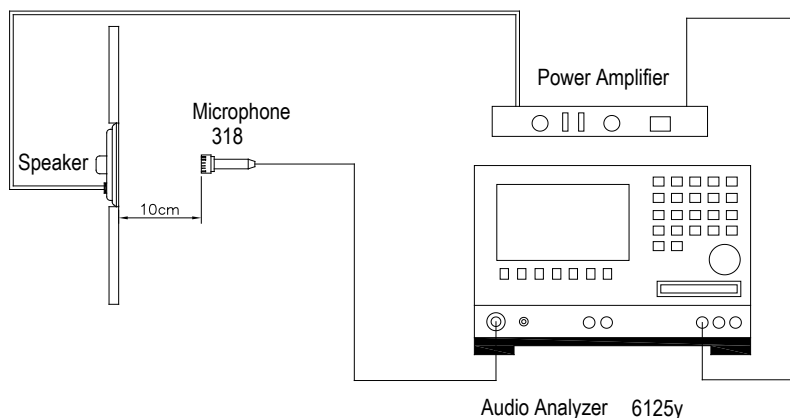

TEST CONDITION	
STANDARD	
temperature	15 ~ 35°C
relative humidity	45% ~ 85%
atmospheric pressure	860mbar to 1060mbar.
STANDARD TEST FIXTURE	
input power	0.1W (0.89V)
zero level	-dB
mode	TSR
potentiometer range	50dB
sweep time	0.5sec



MODEL: SP-1810
PRODUCT: Dynamic Speaker
EDITION: A/2016

TYPICAL FREQUENCY RESPONSE CURVE (Figure 2)





MODEL: SP-1810
PRODUCT: Dynamic Speaker
EDITION: A/2016

Soberton Inc.

RELIABILITY TESTS

The sound pressure as specified shall neither deviate more than $\pm 3\text{dB}$ from the initial value, nor have any significant damage after any of following testing.

HIGH TEMPERATURE TEST

high temperature	$+60\pm 2^{\circ}\text{C}$
duration	96 hours

LOW TEMPERATURE TEST

low temperature	$-20\pm 2^{\circ}\text{C}$
duration	96 hours

HEAT SHOCK TEST

high temperature	$+60\pm 2^{\circ}\text{C}$
low temperature	$-20\pm 2^{\circ}\text{C}$
duration	1 hour
changeover time	< 30 seconds
cycle	100

HUMIDITY TEST

temperature	$+40\pm 2^{\circ}\text{C}$
relative humidity	90~95%
duration	96 hours

TEMPERATURE CYCLE TEST

temperature	-20°C	$+60^{\circ}\text{C}$
duration	45 minutes	45 minutes
temperature gradient	1~3 $^{\circ}\text{C}/\text{min}$.	
cycle	25	

DROP TEST

mounted with dummy set mass	100 g
height	1.5 m
cycle	6 (1 each plain) onto the concrete board

LOAD TEST

noise signal	White noise (EIA filter)
input power	0.5W
duration	96 hours



MODEL: SP-1810
PRODUCT: Dynamic Speaker
EDITION: A/2016

DIMENSIONS

Tolerance: ± 0.5 (unit: mm)

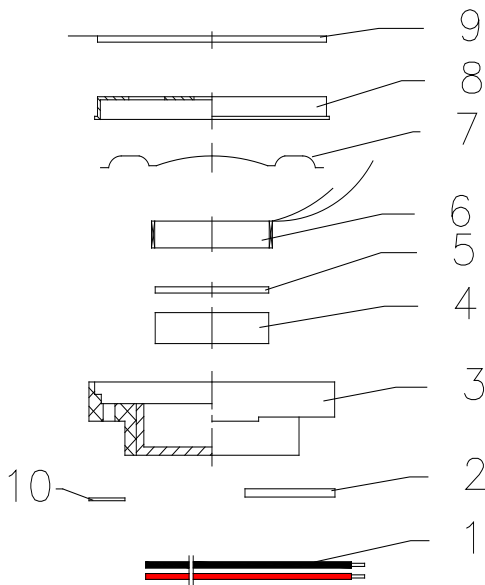
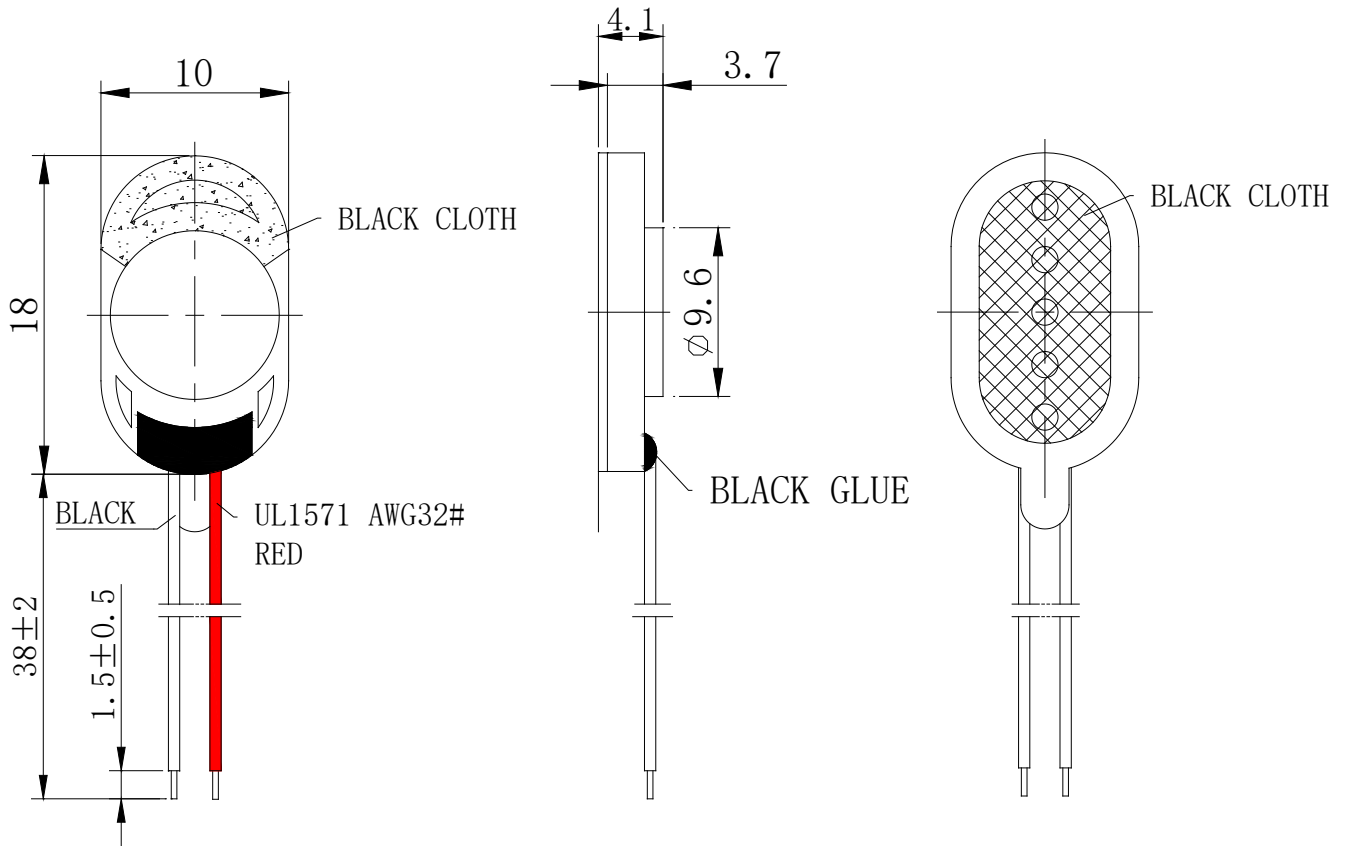

no	item	material	quantity
1	UL1571 AWG30#	Red/Black	2
2	PCB	FR-4	1
3	Frame	PBT	1
4	Magnet	ND Fe B-N38	1
5	Plate	SPCC	1
6	Voice Coil	Copper	1
7	Membrane	PEN	1
8	Cap	Stainless steel	1
9	Gasket	black cloth	1
10	Screen	black cloth	1



MODEL: SP-1810
PRODUCT: Dynamic Speaker
EDITION: A/2016

Soberton Inc.

PACKING

