

DATE	REV	ECN	APP'D. BY
03-09-04	D1	6351	JMB
1-16-06	D2	7440	JM
2-06-09	D3	8652	TA
2-8-11	D4	9125	SMN

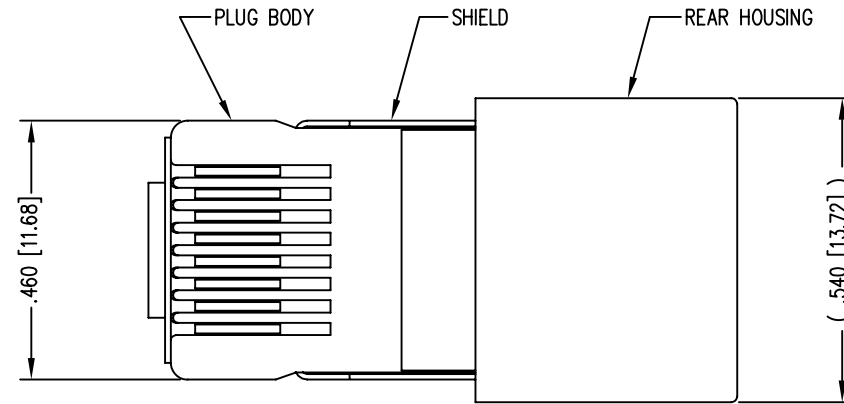

(SHOWN ASSEMBLED)

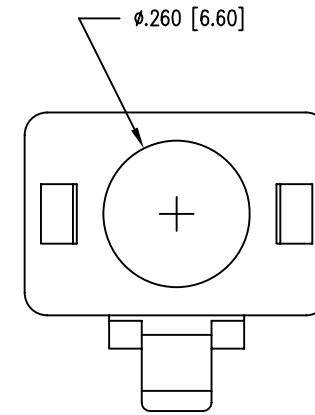
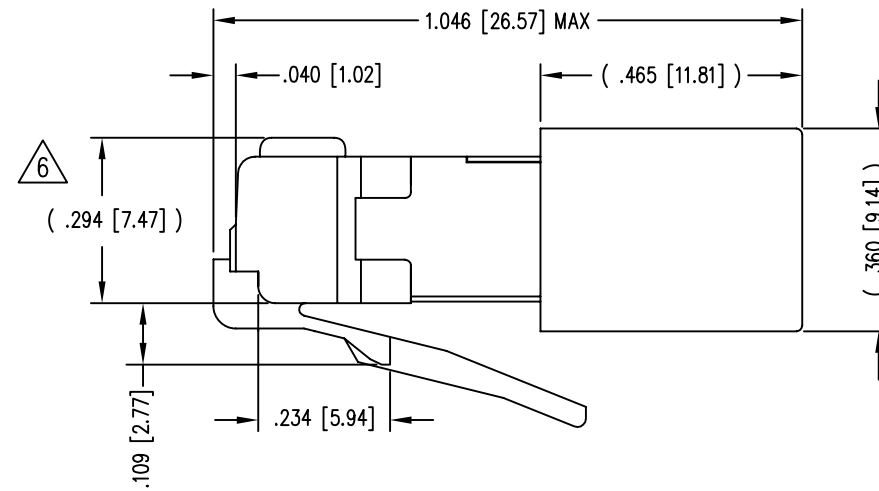
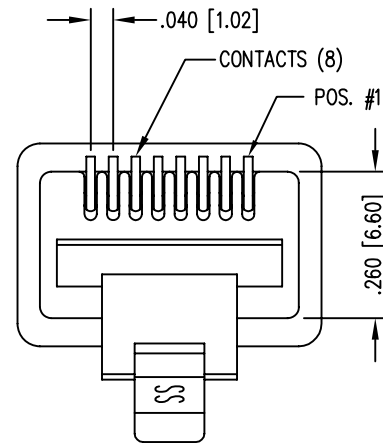

NOTES:

- 1- PLUG KIT CONSISTS OF :
PRE-INSERTED PLUG HOUSING & SHIELD
LOAD BAR
REAR HOUSING
FERRULE
- 2- MATERIALS :
FRONT HOUSING PLASTIC : CLEAR POLYCARBONATE, UL 94-V0
LOAD BAR : CLEAR POLYCARBONATE, UL 94-V0
REAR HOUSING PLASTIC : BLACK POLYCARBONATE, UL 94-V0
SHIELD : TIN PLATED BRASS
CONTACTS : PHOSPHOR BRONZE, SELECTIVE GOLD PLATING
FERRULE : NICKEL OR TIN PLATED BRASS
- 3- CONTACTS TERMINATE STRANDED CONDUCTORS UP TO .037 [0.94] OUTSIDE DIAMETER OF INSULATION.
- 4- FOR PLUG SPECIFICATION SEE PRO26-01.
- 5- DIMENSIONS AND TOLERANCES COMPLY WITH TIA-1096 STANDARD
- △ TERMINATED PLUG HEIGHT: .237 [6.02] ±.005 [0.13] ON CABLE

BULK	50 MICRO-INCHES [1.27um]	940-SP-360808-A108
PACKAGE	CONTACT PLATING IN MATING AREA	PART NUMBER

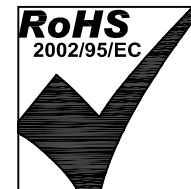
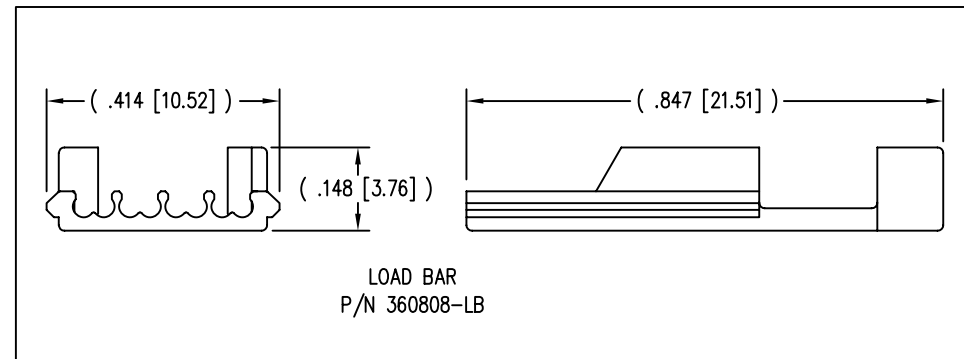
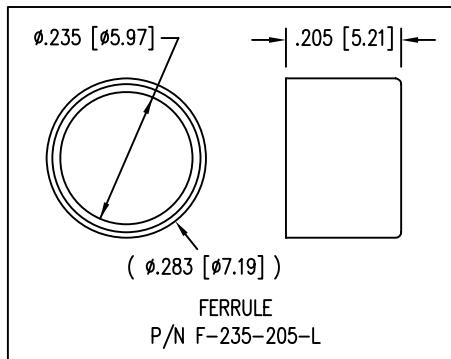

THIRD ANGLE PROJECTION

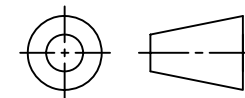

DO NOT SCALE DRAWING
DRAWING IS SUBJECT TO
CHANGE WITHOUT NOTICE

DIMENSIONS: INCHES [METRIC]

UNLESS OTHERWISE SPECIFIED
TOLERANCES ARE ±.005 [0.13]
ANGLES ARE ± 1°

SHEET NO. 1 OF 1

Bel Stewart Connector

11118 Susquehanna Trail South
Glen Rock, PA 17327-9199
(717) 235-7512 Fax: (717) 235-7954 <http://www.stewartconnector.com>

TITLE: 8 POSITION/8 CONDUCTOR STANDARD SHIELDED PLUG ASSEMBLY

THIS DRAWING AND THE SUBJECT MATTER SHOWN THEREON ARE CONFIDENTIAL AND THE PROPRIETARY PROPERTY OF BEL STEWART CONNECTOR AND SHALL NOT BE REPRODUCED, COPIED, OR USED IN ANY MANNER WITHOUT PRIOR WRITTEN CONSENT OF BEL STEWART CONNECTOR. THE SUBJECT MATTER MAY BE PATENTED OR A PATENT MAY BE PENDING.

DRN BY:	TRM	DATE	1-23-03
APPD BY:	RGC	DATE	1-24-03
DWG NO.	CT360035	REV.	D4